

---

## Dynamic Smart Alert Service for Women Safety System

1.M. Pradeep, 2.R. Abinya, 3.S. Sathya Anandhi and 4.S. Soundarya

1.Assistant Professor, Sasurie Academy of Engineering, Coimbatore.

2.Student, Sasurie Academy of Engineering, Coimbatore.

3.Student, Sasurie Academy of Engineering, Coimbatore.

4.Student, Sasurie Academy of Engineering, Coimbatore.

**Received:** 10-09-2017, **Revised:** 17-10-2017, **Accepted:** 09-11-2017, **Published online:** 23-12-2017

---

### Abstract

In recent scenario women in our country are facing a lot of problems such as unethical physical harassment and acid attack in public areas(railway, bus stands, footpaths etc) It rises the need to provide security for women which is considered as a major concern and challenge in our country. This paper has been retransformed the existing systems to provide advancement in the design. The gadget includes sensors for acid attack and physical harassment. It has GSM and GPS module for locating the victim. The kit can be converted to chip using system on chip (SOC) technology. Thus using the VLSI technology, the gadget can be modified to wearable devices such as smart watches bracelets, chains, belts, etc.

---

**Keywords---** GPS, GSM, PIC Microcontroller.

### I. Introduction

India is the fastest growing economic power. Women play a vital role in achieving the nation's goal. Women have adorned high offices in India including that of the president, prime minister, leader of the opposition and speaker of the Lok Sabha. But the safety of women is the major concern for many decades. They are facing much physical and mental harassment problems. In today's world women's are less secure, they are facing more number of situations like kidnapping, rape case, abuse and acid attack. Because of this reasons women's can't step out of their house.

Problems may come from any direction such as women walking on the road after the work, going to super market or many other reasons for which they go alone. People at home are not sure

of their return safely. In 2013 there happened an incident which is a gang rape in New Delhi in the case of 23 year old woman in bus at 9:30 PM. Another incident that has taken place at Mumbai in the case of woman who is leaving her native place after Christmas holidays has been kidnapped and killed. Acid attack is also one of the most violent crimes against women. It has been estimated that around a thousand of women suffers acid attack per year in India. Recently a female constable in Tamilnadu's Vellore district was attacked with acid by masked men. The year 2016 saw a never-before 309 acid attack incidents being reported from across the country.

These are some of the problems that have taken place in the day to day life of women. In recent years WHO reports that many women had

been subjected to sexual harassment. As per the report of National Crime Records Bureau of India, the crime against women is increasing drastically and going beyond control.

Not only in India, there is a universal truth applicable to all other countries: violence against is never acceptable and never excusable. The report of WHO states that. "A violence act against female gender distributed the public health life of society and also it violates the human rights of women". The prime question in every woman's mind, taking into account the ever rising increase of issue on women harassment in recent past, is only about her safety and security.

In this fast growing technological world, a prime need arises for providing safety. The only thought in women's mind is where they will be able to move freely on the streets even in night hours without worrying about their security. Thus the aim of this project is to develop a wearable device for the safety and protection of women and girls. It is a simple gadget designed solely to serve the purpose of providing security to women mainly against acid attack and sexual assault. The chip consist of various modules such as GPS, GSM, and screaming alarm, PIC controller, spy camera and sensors for acid concentration, temperature, vibration, etc. This paper is organized as follows. Section II analyses the existing system section III describes the proposed model section IV presents the

result analysis. In section V, future scope of the proposed system is discussed and finally section VI presents the conclusion of this paper.

## **II. Literature Review**

The detail analysis from the various sources has been studied and understood as shown

### **A. Mobile Application for Women's Safety: WoSApp**

WoSApp (Women's Safety App) that provides women with a reliable way to place an emergency call to the police. The user can easily and discreetly trigger the calling function by shaking her phone or by a simple press of a PANIC button on the screen. A message containing the geographic location of the user, as well as contact details of a pre-selected list of emergency contacts, is immediately sent to the police [1].

### **B. Women Security System using GSM and GPS**

This system designs a portable device which has force sensor that detects by the threshold value applied to women. The metal detector detects the presence of metals like knife and other things present with the kidnappers and with help of shocking circuit, the shock was applied to the kidnappers [2].

### **C. Smart Girl Security System**

This system provides a portable device which resembles a normal belt. It consists of Arduino Board, GSM/GPS modules, screaming alarm and pressure sensors. When the threshold of the pressure sensor crosses, the device will get

activated automatically. Immediately the location of the victim will be tracked with the help of GPS and emergency messages will be sent to three contacts and one to police control room every two minutes with updated location. The screaming alarm unit will be activated and will send out sirens to call out for help. The system is also capable to generate an electric shock to harm the attacker which may help the victim to escape [3].

#### **D. Self Defense System for Women Safety with Location Tracking and SMS Alerting Through GSM Network**

Self Defense System for women safety is like a Smart Watch for Women. It has the ability to help women with technologies that are embedded into a compact device. The women wearing this device as a watch or band, in case of any harassment or when she finds that someone is going to harass, she presses a switch that is located on the watch or band or when the woman has fallen the information about the attack along with the body posture and location information is sent as SMS alert to a few predefined emergency numbers And soon help is on its way! The system will consist of embedded hardware and software co-designed for this dedicated application. The system allows for knowing exact location of the individual, as soon as the trigger key on the belt is pressed. By providing the instant location of the distressed victim to the police so that the incident could be prevented and culprit apprehended. In case if the caretaker wants to know the present location of

the lady, he/she can do so by sending a SMS to the SIM number of the lady which contains a secret password. Then this system responds to such request by sending back a SMS containing location information in terms of Latitude and Longitude. This would help reduce crime against women. It also contains a shock mechanism to produce non-lethal electric shock in emergency situations to deter the attacker [4].

#### **E. Design and implementation of Safety Armband for Women and Children using ARM7**

The paper proposes an automatic cum manual device which would help the victim to alert others during emergency situations and also collect evidences in the form of video. The proposed prototype can be turned ON by an action of human hand (twisting of Wrist). This is because it is not necessary a victim will always have freedom to turn on the system manually. The system proposed has three options for the victim to turn it ON. If the victim has a degree of freedom to turn ON the system, then a simple switch can be used to turn the system ON. When a person is attacked or in a dangerous [5].

### **III. System Architecture**

This project proposed a new model for the women security in public places which aims to provide the maximum safe environment in acid attacks and unethical physical harassment. This module consists of PIC Microcontroller, acid detection sensor, temperature and vibration sensor, spy camera, GPS and GSM modules.

This security system can perform and execute certain operations such as:

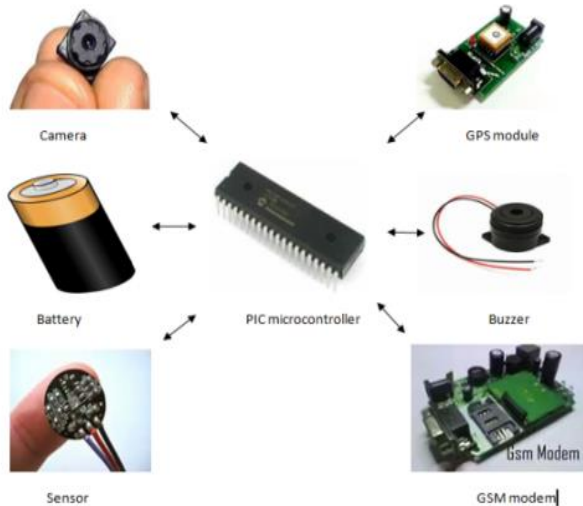

- 1) Measures accurate location.
- 2) Alarm is turned on during the attack.
- 3) Messages can be sent to the control room.
- 4) Images are captured.
- 5) Acid can be detected.
- 6) Measures heart beat rate and temperature.

**A. System Implementation**

The system consists of embedded hardware and software co- designed for this application. As soon as the acid is detected, the hidden camera captures the images of the stranger and sends the exact location with the captured image to the control room. The gadget also provides an alarm system, to call out for help. The block diagram of this system is shown as follows:

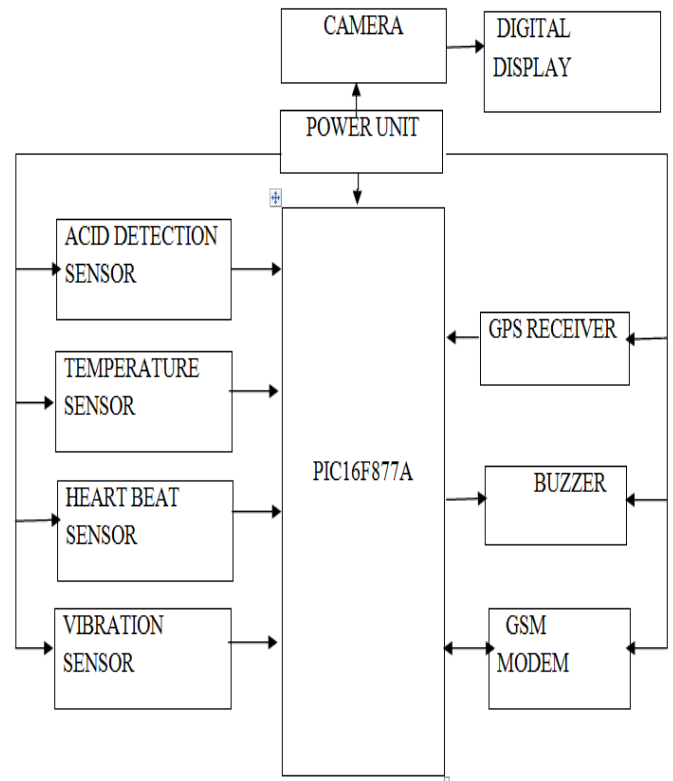

**IV. Hardware Description**

**A. PIC Micro Controller**

PIC 16F877 is a 40-pin 8-Bit CMOS FLASH Microcontroller from Microchip. The core architecture is high-performance RISC CPU with only 35 single word<sup>1</sup> instructions. Since it follows the RISC architecture, all single cycle instructions take only one instruction cycle except for program branches which take two cycles. 16F877 comes with 3 operating speeds with 4, 8, or 20 MHz clock input. Since each instruction cycle takes four operating clock cycles, each instruction takes 0.2 μ s when 20MHz oscillator is used.

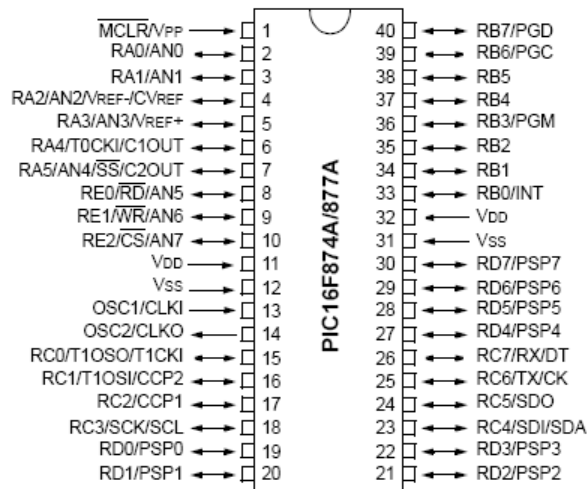

It has two types of internal memories: program memory and data memory. Program memory is provided by 8K words (or 8K\*14 bits) of FLASH Memory, and data memory has two sources. One type of data memory is a 368-byte RAM (random access memory) and the other is 256-byte EEPROM (Electrically erasable programmable ROM).

The core feature includes interrupt capability up to 14 sources, power saving SLEEP mode, and single 5V In-Circuit Serial Programming (ICSP) capability. The sink/source current, which indicates a driving power from I/O port, is high with 25mA. Power consumption is less than 2 mA in 5V operating condition.

The peripheral features include:

- 1) 3 time blocks: Timer0 for 8-bit timer/counter; Timer1 for 16-bit timer/counter; and Timer2: 8-bit timer/counter with 8-bit period register, pre scalar and post scalar.

- 2) Two Capture, Compare, PWM modules for capturing, comparing 16-bit, and PWM generation with 10-bit resolution.
- 3) 10-bit multi-channel (max 8) Analog-to-Digital converter module.
- 4) Synchronous Serial Port (SSP) with SPI (Master Mode) and I2C2 (Master/Slave)
- 5) Universal Synchronous Asynchronous Receiver Transmitter (USART/SCI) with 9-bit address detection
- 6) Parallel Slave Port (PSP) 8-bits wide, with external RD, WR and CS controls
- 7) I/O ports.

#### **B. Acid sensor**

ACID detector is a device that detects gas. Commercial, industrial, and mass residential devices issue a signal to a fire alarm system, while household detectors, known as Acid alarms, generally issue a local audible and/or visual alarm from the detector itself.

Resistance value of sensor is difference to various kinds and various concentration gases. So, when using these components, sensitivity adjustment is very necessary. we recommend that you calibrate the detector for 1000ppm of ACID concentration in air and use value of Load resistance (  $R_L$ ) about  $20K\Omega$  ( $10K\Omega$  to  $47K\Omega$ ). When accurately measuring, the proper alarm point for the gas detector should be determined after considering the temperature and humidity influence.

**C. Tilt sensor**

Tilt sensor comprises of temperature and heart beat sensors. Heartbeat sensor is used to monitor the heart beat and pulse rate. It is based on the principle of photo phlethysmography. LM35 temperature sensor was used in this project. We integrated this with the PIC to measure the temperature period. The microcontroller will then read this measured value from the LM35 and translate into degrees Fahrenheit and Celsius, which we will be able to read from the MCU to the LCD. LM35 is placed in contact with the human body.

**D. GPS Module**

Global Positioning System is a navigation and precise positioning tool, tracks the location in the form of longitude and latitude based. The GPS Coder Module used this information to search an exact address of that location as the street name, nearby junction etc. In case where GPS is disabled then the system will only send the longitude and latitude. Internet is mandatory.

**E. GSM System Module**

Global System for Mobile communication (GSM) SIM card is inserted inside the mobile device to send and receive the messages using GPRS. The GSM SIM card number is registered with the system. With increasing usage of GSM, network services are expanded beyond speech communication to incorporate many other custom applications, machine automation and machine to machine communication.

**F. Wireless Camera**

Wireless camera is a hidden camera used to capture the images of the stranger and sends to the control room as a message. The camera can be in the form of ornaments or any wearable devices.

**G. LCD Module**

16x2 LCD module is a very common type of

LCD module that is used in 8051 based embedded projects. It consists of 16 rows and 2 columns of 5x7 or 5x8 LCD dot matrices. It is available in a 16 pin package with back light, contrast adjustment function and each dot matrix has 5x8 dot resolution.



## V. Software Description

### MPLAB Compiler

MPLAB is a proprietary freeware integrated development environment for the development of embedded applications on PIC and dsPIC microcontrollers and is developed by microchip technology. MPLAB 8.X is the latest version, that supports project management, editing, debugging and programming of microchip 8 bit, 16 bit and 32 bit PIC microcontrollers.

## VI. Result Analysis

The proposed system was successfully implemented in both hardware and software. The simulation of working of the system is as follows

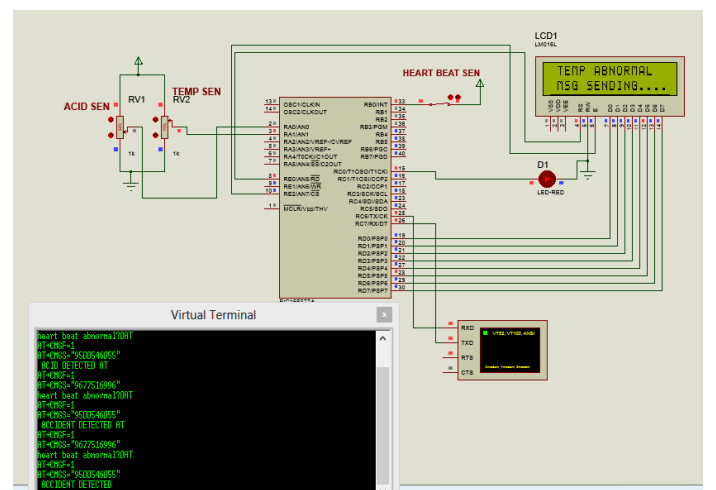
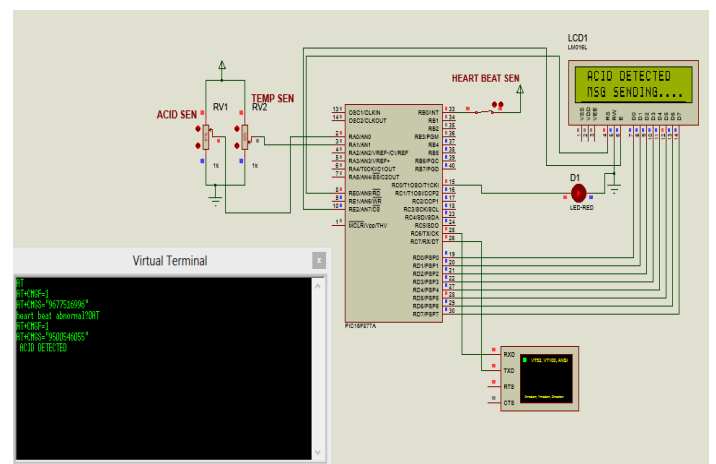
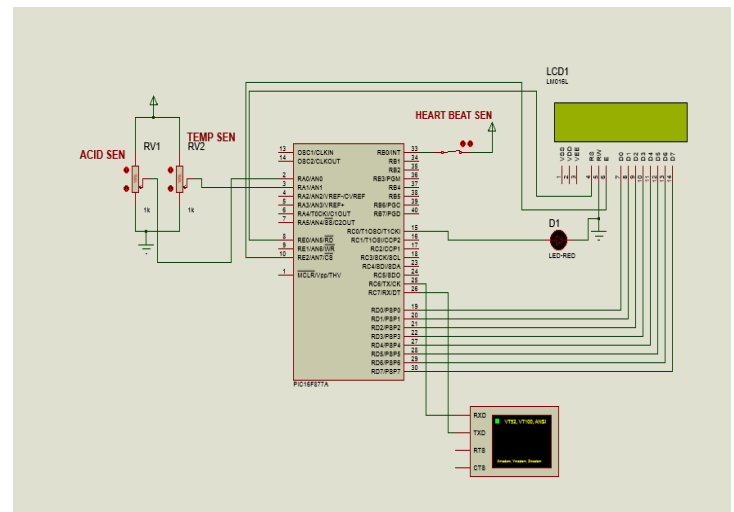

## VII. Future Scope

As the technological changes or new requirement from user to enhance the

functionality of product may requires new version to introduce. Although the System is complete and working efficiently, new modules which enhance the system functionality can be added without any major changes to the entire system. By keeping this ability of the product I mind, an incremental process model has been used to design and develop the system.

#### **Primary School Children Safety**

As the school children safety are major concerns for parents as well as school management due to the recent incidents of child crimes like children missing, abuse etc. This module monitors the child safety when they are travelling in school buses. Once they reached the school the device gets deactivated by school authority and message send the parents that, “the child reaches the school safely”. At return journey again the device is activated by school authority and when they reached the home, the acknowledge message is send to the school when parents deactivate the device. The device is capable of audio recording when activated that can be listening by the parents or authorize person.

#### **Vehicle Safety System Module**

The Safety of four wheeler car is also a major concern in the society due to the increase in the crime rate of stolen car. The intrusion detection module can be modified according to the requirement of vehicle safety system module.

#### **Mobile and Other Valuables Safety System Module**

The missing rate of mobiles is high while travelling from bus, train or crowd public area. The area zone module functionality further enhances to provide safety. A small device needed to keep either in same pocket or within the range of few centimeters. As you kept the mobile and forget to pick up or someone stolen it then de to small range the siren of mobile as well as device gets ON for user attention.

Also the same device can attach to our luggage, hence in case of forgetting to pick back or try to stolen by someone can be easily noticed by the module and make the attention of user through the siren alarm.

Hence, the advance technology makes the system more robust and reliable. As the new modules provide the functionality which enhance the safety and security. Thus it helps to fulfill the purpose of the project.

### **VIII. Conclusion**

It can be concluded that the system helps to supports the gender equality by providing safe environment to women in the society, and allows them to work till late nights. Anyone before doing any crime against the women will be deterred and it help reducing the crime rate against the women.

The proposed system provides the tool for intrusion detection inside the home where senior citizen, handicapped person or women leaving alone and after detection of intrusion it takes



necessary preventive measure action to ensure safety

The propose system provides the area zone modules to provides the child security and surveillance such as the child abuse and child missing crime rate in the society is high and protection measure is needed to provide them a safety.

The image of the stranger captured by the wireless camera stores the data onto the cloud. There is a need to make such systems standard and get approval from government, so that courts accept the evidences.

Women's security is a critical and social issue in today's world. The crime (molestations, robbery, sexual assault, rape, domestic violence) against the women can be now brought to an end with the help of real system implementation of propose model.

## References

- [1] Jijesh, J. J., et al. "A method for the personal safety in real scenario." *Computation System and Information Technology for Sustainable Solutions (CSITSS), International Conference on*. IEEE, 2016.
- [2] Suganthi, J., N. V. Umareddy, and Nitin Awasthi. "Medical alert systems with TeleHealth & telemedicine monitoring using GSM and GPS technology." *Computing Communication & Networking Technologies (ICCCNT), 2012 Third International Conference on*. IEEE, 2012.
- [3] Chougula, Basavaraj, et al. "Smart girls security system." *International Journal of Application or Innovation in Engineering & Management* 3.4 (2014).
- [4] Chand, Dhruv, et al. "A mobile application for Women's Safety: WoSApp." *TENCON 2015-2015 IEEE Region 10 Conference*. IEEE, 2015.
- [5] Toney, Glenson, Fathima Jabeen, and S. Puneeth. "Design and implementation of safety armband

- for women and children using ARM7." *Power and Advanced Control Engineering (ICPACE), 2015 International Conference on*. IEEE, 2015.
- [6] Rana, GM Sultan Mahmud, et al. "Design and implementation of a GSM based remote home security and appliance control system." *Advances in Electrical Engineering (ICAEE), 2013 International Conference on*. IEEE, 2013.
- [7] Pawar, Sampat S., and P. C. Bhaskar. "Design and Development of ARM based Real-Time Industry Automation System using GSM." (2015).